

# Trojan Type-‘M’

AIR POWERED PUMP

OPERATING AND MAINTENANCE  
INSTRUCTIONS



ATEX  II 2G Ex h IIC T5 Gb  
II 2D Ex h IIC T 100°C Db

## THE Trojan TYPE 'M'

**DESCRIPTION** This unit is a reciprocating piston pump powered by compressed air. It basically consists of a pneumatic piston and hydraulic ram which is linked to a four way air valve which causes the pump to reciprocate. Inlet and outlet non-return valves fitted to the hydraulic cylinder turn the displacement of the ram into a pumping action. The area of the piston is greater than that of the ram and this difference in area is the pump ratio.

If the hydraulic outlet is blocked off completely, say during pressure testing of a component, then the hydraulic pressure within the system will be the driving air pressure multiplied by the pump ratio. (Eg. a 2 Bar air pressure in a pump of ratio 25:1 will give a 50 Bar hydraulic pressure, less a small amount due to friction.)

**INSTALLATION** The pump will operate in any position, and can either be used free standing or bolted down.

An air line is connected to the air inlet of the pump.

An air filter should be included in the air line and though not essential the life of the pump will be extended by the use of an air lubricator.

An air pressure regulator will give control of the hydraulic outlet pressure.

The hydraulic fluid is connected to the inlet non-return valve (see direction of flow arrows on the assembly drawing).

Including a suitably sized strainer in the inlet pipework will prevent expensive damage from possible contaminants.

It is always advisable for the fluid reservoir to be higher than the pump.

The hydraulic outlet non-return valve is connected to the high pressure hydraulic system.

Pressure Equipment Directive 2014/68/EU Categories:-

Ratios 4.4:1 to 53:1	SEP
Ratios 79:1 & 114:1	SEP (Group 2 liquids only)
Ratios 159:1 to 400:1	Category I (Group 2 liquids only)

**PIPEWORK** The size of the pipework should be comparable to the size of the threads on the non-return valves.

The pressure rating and type of pipe should be suited to the particular application.

All pipework should be checked that it is clean and free from burrs before connecting to the pump.

### **OPERATION**

**The air pressure applied to the pump must never exceed 8 bar.**

The pump is started by turning on the air pressure.

If using for the first time, or if it is suspected that air has got into the hydraulic side of the pump it must first be primed to remove any air out of the system by allowing the pump to run with the hydraulic outlet unrestricted until all air has been expelled.

**Do not allow the pump to run for long periods with no liquid passing through it as this will cause the main seal to overheat and fail.**

The pump can be stopped at any time by turning the air supply off, or it will eventually stall itself when the hydraulic test pressure set by the air pressure regulator is reached; in this state no further air will be used until the hydraulic pressure drops and the pump automatically re-starts.

**MAINTENANCE** To keep the pump in good condition it is only necessary to ensure that it is fed with a clean and filtered air supply, and the liquid fed into the pump is free of any contaminants that could cause wear. Though not essential, fitting an air lubricator will extend the service interval of the pump but if one is fitted it is important that it is kept filled.

**FREEZING !** Care must be taken in extremely cold conditions to prevent the risk of freezing, if water is being used as the hydraulic medium.

**SPARES** When ordering spare parts it is essential to quote the pump type and ratio and if possible the serial number. This information will be found on a label fixed to the pump.

Pumps and spares are all available from:-

Hydraulic Pneumatic Services Ltd,  
Unit 17, King Street Trading Estate  
Middlewich, Cheshire UK, CW10 9LF

Tel: +44 (0)1606 835725      [www.trojanpumps.com](http://www.trojanpumps.com)

## SERVICING

### To Change the Hydraulic Seal and Air Piston O' Ring.

- a) Disconnect the air supply from the pump!
- b) Unscrew the retaining nuts on the two air elbows (item 7), remove the four retaining bolts (item 40). The two halves of the pump can now be pulled apart. Remove the air cylinder (item 8) by sliding it off the air piston (item 6) and pull the piston assembly along with the hydraulic ram (item 47) out of the pump. On ratios 1:38 and lower the main hydraulic seal is held on the end of the ram by a screw (item 51) and washer. Higher ratios use a retaining-ring (item 45) with two peg spanner holes to retain the seal in the hydraulic cylinder. This should be unscrewed using a suitable Pin Type Face Spanner. During re-assembly all sliding surfaces should be lubricated with a general purpose grease except for the hydraulic Ram item 47 on the 400:1 pump which should be lubricated with oil.

### Servicing the air change over valve.

- a) Disconnect the air supply from the pump!
- b) Separate the two halves of the pump as described above. Remove the pilot bush retaining circlip (item 4) and carefully pull the bush from the housing. The main air valve is dismantled by removing the end caps (items 20 & 29) and sliding the internal seals etc. out. The end caps will retain the pistons which should also be pulled out and examined. Make careful note as to the order in which the various components are fitted. The two end caps are designed in such a way that it is impossible to fit them incorrectly. The return end cap is fitted with a small O' Ring (item 27) to seal the pilot hole, the other end cap has no O' Ring. This is correct and no attempt should be made to seal this hole.

During re-assembly all sliding surfaces should be lubricated with a general purpose grease.

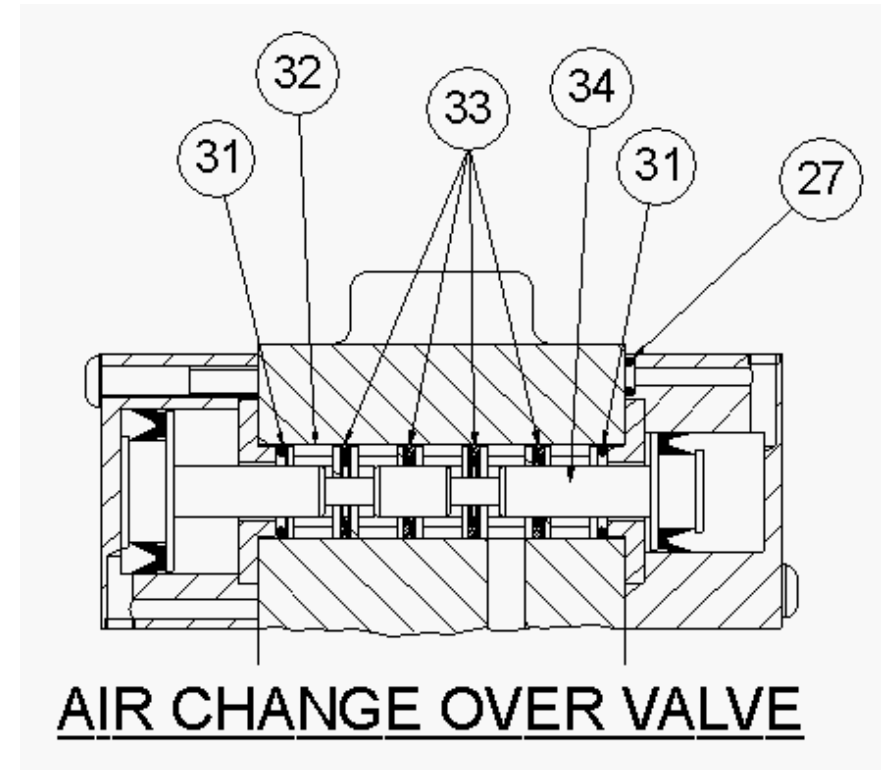

- 27 O' Ring
- 31 O' Ring
- 32 Cage
- 33 Sealing Ring
- 34 Valve Spool

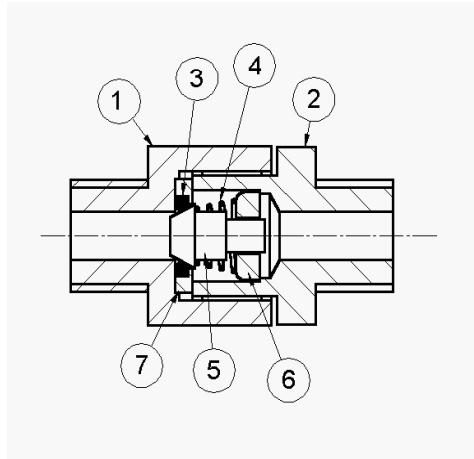

NON RETURN VALVE FITTED TO RATIOS 1:4.4 - 1:159

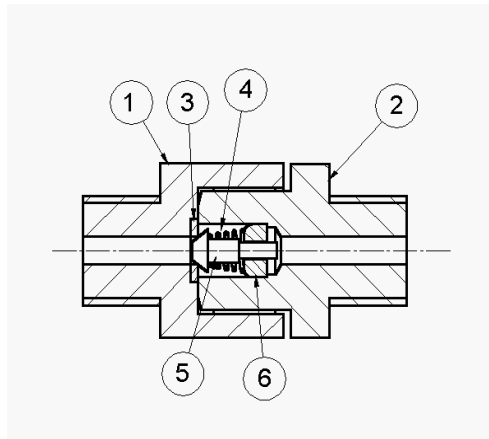

NON RETURN VALVE FITTED TO RATIO 1:256 & 1:400

## SERVICING

### To Service the Non-Return (Check) Valves.

- a) Disconnect the air supply from the pump!
- b) Unscrew the Non-Return Valves (items 60 & 61) from the pump. Grip the wider part of the Valve, the Seat (item 1) in a sturdy vice using soft jaws to protect the valve from damage. Using a large spanner unscrew the Valve Body (item 2) and separate the two halves of the Valve.

During reassembly place the Body of the Valve (item 2) with the open end upwards in a vice. Insert the Guide (item 6), Spring, (item 4) wide end against the Guide, Poppet (item 5) into position then place the Seal Retainer (item 7) fitted with a new O' Ring on top of the Poppet, be sure this is the correct way round. (Note:- Ratios 256:1 & 400:1 have the Seal Ring (item 3) placed directly into the Seat of the Valve (item 1).

Apply anti-seize grease to the threads and carefully lower the Seat (item 1) into position and screw the two parts together.

Grip the Valve in a vice as before and tighten fully.

### IMPORTANT

Before refitting the Non-Return Valves to the pump you need to seat the Poppets onto the seals. A suitably sized rod. is inserted through the Body (item 2) and pushed firmly against the end of the Poppet forcing it onto the Seal.

The INLET valve has the NARROW hexagon against the pump body, the OUTLET valve has the WIDE hexagon against the pump body.

Items highlighted in YELLOW are included in the Pneumatic Service Kit 10098KPS.  
 Items highlighted in BLUE, along with the Poppets Seals and Springs from the Check Valves are included in the Hydraulic Service Kit 10098KH/(Ratio).

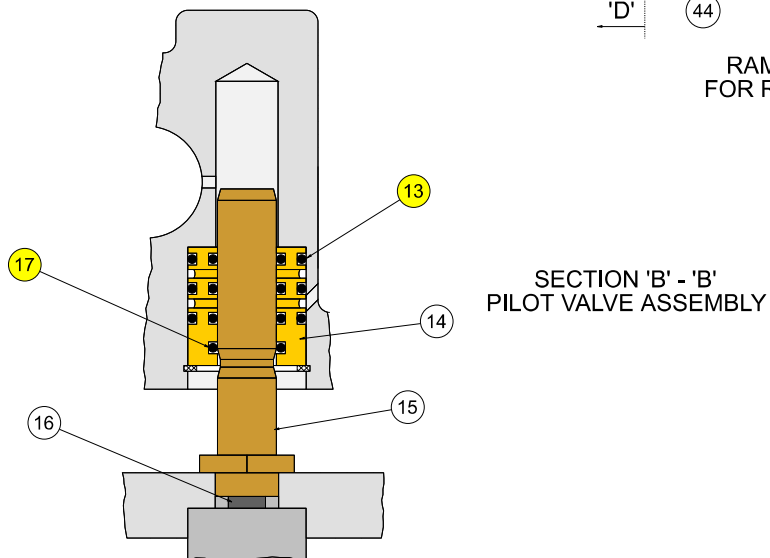
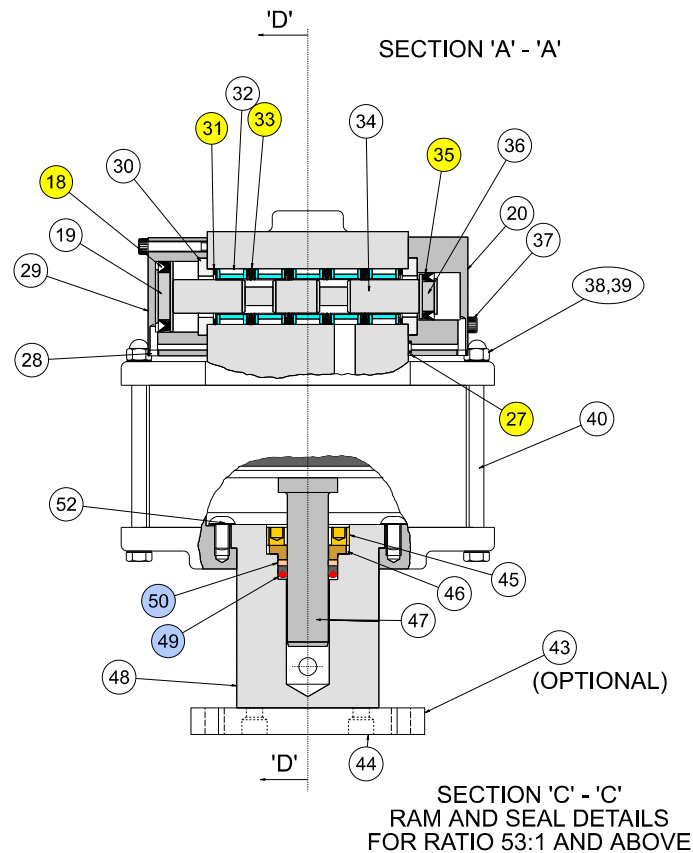
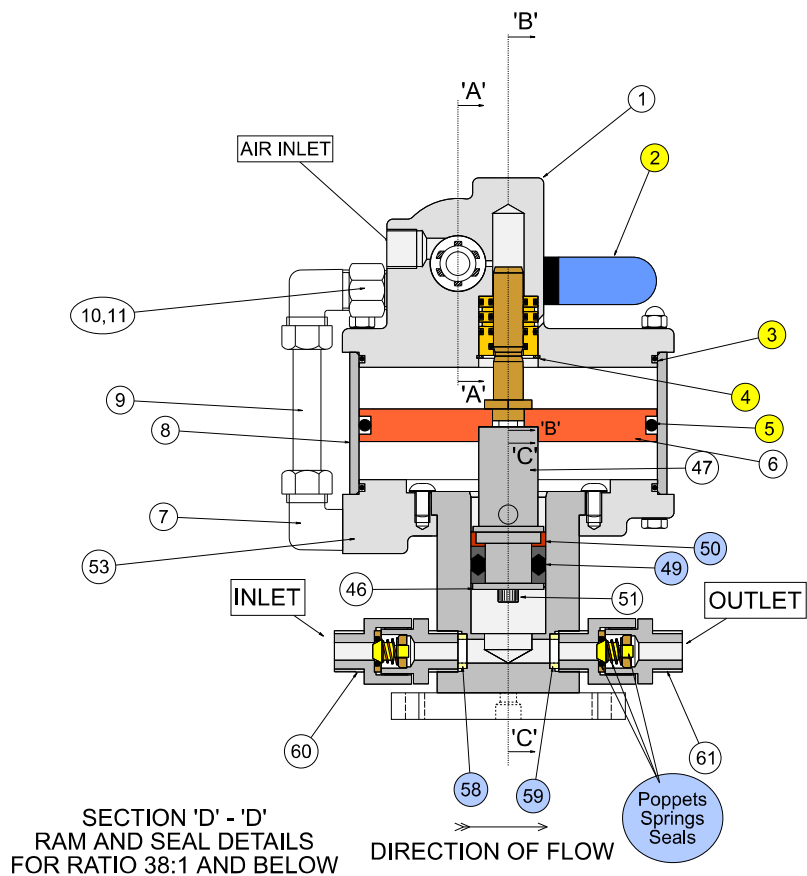

**IMPORTANT**  
 Before refitting the Non-Return Valves to the pump you need to seat the poppets onto the seals. A suitably sized rod is inserted through the Body and pushed firmly against the end of the poppet forcing it onto the Seal.

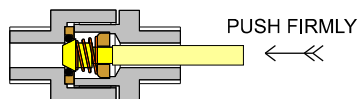

66		
65		
64		
63		
62		
61	OUTLET N.R.VALVE	1
60	INLET N.R. VALVE	1
59	OUTLET PORT WASHER	1
58	INLET PORT WASHER	1
57		
56		
55		
54		
53	BOTTOM COVER	1
52	SCREW	4
51	SCREW	1
50	ANT-EXTRUSION RING	1
49	HYDRAULIC SEAL	1
48	HYDRAULIC CYLINDER	1
47	RAM	1
46	BACK UP RING	1
45	LOCK RING	1
44	SCREW (WITH ITEM 43)	2
43	BASE (OPTIONAL)	1
42	RIVET	4
41	LABEL	1
40	BOLT	6
39	WASHER	12
38	DOME NUT	6
37	SCREW	6
36	RETURN PISTON	1
35	U' RING	1
34	MAIN VALVE SPOOL	1
33	SEALING RING	4
32	CAGE	5
31	O' RING	2
30	LOCATING DISC	2
29	END CAP, SIGNAL	1
28	PLUG	2
27	O' RING	1
26		
25		
24		
23		
22		
21		
20	END CAP, RETURN	1
19	SIGNAL PISTON	1
18	U' RING	1
17	O' RING	4
16	CONNECTING STUD	1
15	PILOT SHAFT	1
14	BUSH	1
13	O' RING	3
12		
11	WASHER	1
10	ADAPTOR	1
9	AIR PIPE	1
8	AIR CYLINDER	1
7	ELBOW	2
6	PISTON	1
5	O' RING	1
4	CIRLCLIP	1
3	O' RING	2
2	SILENCER	2
1	TOP COVER/VALVE BODY	1
ITEM	DESCRIPTION	QTY.

Hydraulic Pneumatic Services Ltd  
 Unit 17, King Street Trading Estate  
 Middlewich, Cheshire, CW10 9LF (UK)  
 Telephone: +44 (0)1606 835725  
 Web: www.trojanpumps.com.

DRAWN: JAC  
 DATE: 17-4-2001  
 FIRST ANGLE PROJECTION

SCALE: 1:1  
 WHEN PRINTED A0

TITLE:

The **Trojan** Type 'M'

ISSUE 2 : 11-8-04

DRG. No.

10098/2