



Hydraulic Pneumatic Services Ltd

Trojan Type 'J' Portable Power Pack Operating and Maintenance Instructions



(Shown with optional Reservoir & Carrying Handle)

ATEX  II 2G Ex h IIC T5 Gb
II 2D Ex h IIC T 100°C Db

TROJAN Type 'J' PORTABLE POWER PACK

OPERATING INSTRUCTIONS

Pressure Equipment Directive 2014/68/EU Categories:-

Ratios 2.2:1 to 45:1 SEP

Ratios 70:1 & 100:1 SEP (Group 2 liquids only)

Ratio 165:1 Category I (Group 2 liquids only)

PLEASE NOTE: - These instructions are intended as a guide to operating the power pack, it is assumed the operator is familiar with the safe and correct procedure for performing pressure testing.

1/ Ensure there is a supply of hydraulic fluid to the pump, either from the reservoir if fitted, or if not, directly to the inlet strainer.

2/ Turn the knob of the air pressure regulating valve anti-clockwise until it is free and connect a supply of compressed air **not exceeding 8 bar** to the inlet of the air pressure regulator. If using dried air a lubricator must be used.

3/ Using suitable high-pressure pipework and fittings connect the test equipment to the high-pressure outlet of the manifold block.

4/ Open the high-pressure release valve by turning the handle anti-clockwise.

5/ Check the air on/off ball valve is open; when open the handle is in line with the flow of air.

6/ Slowly turn the knob of the air pressure regulator clockwise until the pump starts to operate.

7/ Fluid should soon be pumped out of the high-pressure release valve, allow this to continue for a short time to purge the pump of air.

Do not allow the pump to run for long periods with no liquid passing through it as this will cause the main seal to overheat and fail.

8/ Turn off the air ball valve and close the high-pressure release valve.

9/ If the air ball valve is now opened the pump will start to operate and soon the hydraulic pressure gauge should show a rise in pressure, this pressure will increase up to a set figure which will be approximately the applied air pressure multiplied by the ratio of pump. This pressure can be raised or lowered by altering the air pressure regulator. **The air pressure applied to the pump must never exceed 8 bar.**

10/ After the test is complete the hydraulic pressure can be released by slowly opening the high-pressure release.

MAINTENANCE:-

If water gathers in the air filter/regulator pressing the button at the bottom of the filter bowl will expel it.

Occasionally the liquid inlet strainer should be removed by unscrewing the large nut and the element cleaned.

SERVICING:-

All packings are lubricated when assembled and should not require further lubrication. If the air is filtered and dry, a lubricator should be fitted and kept filled. Indication of dry cylinder O' rings is jerky travel or shuddering of the air piston.

To Change the Hydraulic Seal and Air Piston O' Ring.

- a) Disconnect the air supply from the pump!
- b) Unscrew the retaining nuts on the two air elbows (item 7), remove the four retaining bolts (item 28). The two halves of the pump can now be pulled apart. Remove the air cylinder (item 8) by sliding it off the air piston (item 6) and pull the piston assembly along with the hydraulic ram (item 37) out of the pump. On ratios 1:4.4 and 1:11 the main hydraulic seal is held on the end of the ram by a screw (item 41) and washer. Higher ratios use a retaining-ring (item 45) with two peg spanner holes to retain the seal in the hydraulic cylinder. This should be unscrewed using a suitable Pin Type Face Spanner During re-assemble all sliding surfaces should be lubricated with a general purpose grease.

Servicing the air change over valve.

- a) Disconnect the air supply from the pump!
- b) Separate the two halves of the pump as described above. Remove the pilot bush retaining circlip (item 4) and carefully pull the bush from the housing. The main air valve is dismantled by removing the end caps (items 18 & 31) and sliding the internal seals etc. out. The end caps will retain the pistons which should also be pulled out and examined. Make careful note as to the order in which the various components are fitted. The two end caps are designed in such a way that it is impossible to fit them incorrectly. The return end cap is fitted with a small O' Ring (item 25) to seal the pilot hole, the other end cap has no O' Ring. This is correct and no attempt should be made to seal this hole.

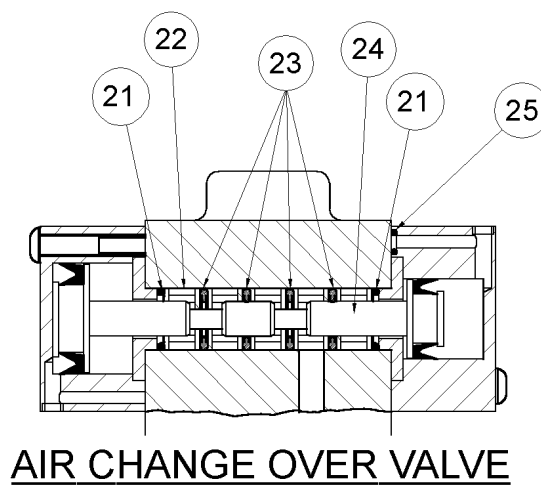

To Service the Non-Return (check) Valves.

- a) Disconnect the air supply from the pump!
- b) Unscrew the Non-Return Valves (items 43) from the pump. Grip the wider part of the Valve, the Seat (item 1) in a sturdy vice using soft jaws to protect the valve from damage. Using a large spanner unscrew the Valve Body (item 2) and separate the two halves of the Valve.

During reassembly place the Body of the Valve (item 2) with the open end upwards in a vice. Insert the Guide (item 6), Spring, (item 4) wide end against the Guide, Poppet (item 5) into position then place the Seal Retainer (item 7) fitted with a new O' Ring on top of the Poppet, be sure this is the correct way round. (Note:- Ratio 165:1 has the Seal Ring (item 3) placed directly into the Seat of the Valve (item 1).

Apply anti-seize grease to the threads and carefully lower the Seat (item 1) into position and screw the two parts together.

Grip the Valve in a vice as before and tighten fully.
Ratios 2.2:1 to 100:1 237 Nm, ratio 165:1 339 Nm.

Before refitting the Non-Return Valves to the pump it is necessary to seat the poppets onto the seats. A suitable rod is inserted through the Body (item 2) and pushed firmly against the end of the poppet forcing it onto the Seal.

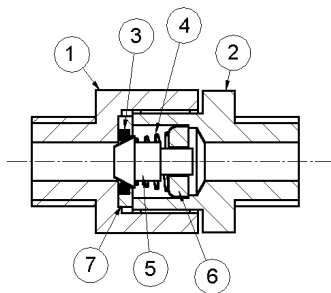

NON RETURN VALVE
FITTED TO RATIOS 1:2.2 - 1:100

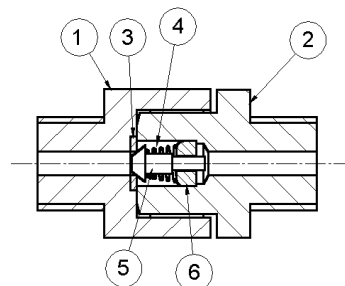

NON RETURN VALVE
FITTED TO RATIO 1:165

Important

- a) Ensure air and L. P. hydraulic supply lines are adequately filtered.
- b) KEEP PUMP CLEAN.
- c) When ordering spares quote the item number and description from the assembly drawing and state the ratio and serial number of the pump.

Pumps and spares are all available from:-

Hydraulic Pneumatic Services Ltd, Unit 17, King Street Trading Estate
Middlewich, Cheshire UK

CW10 9LF

Tel: +44 (0) 1606 835725

www.trojanpumps.com

APPROXIMATE WEIGHT STANDARD = 14kg
 APPROXIMATE WEIGHT WITH RESERVOIR = 20kg

ITEMS MARKED * ON THE PARTS LIST ARE OPTIONAL AND ONLY
 FITTED WHEN THE EQUIPMENT IS SUPPLIED WITH A RESERVOIR

DIMENSIONS ARE APPROXIMATE

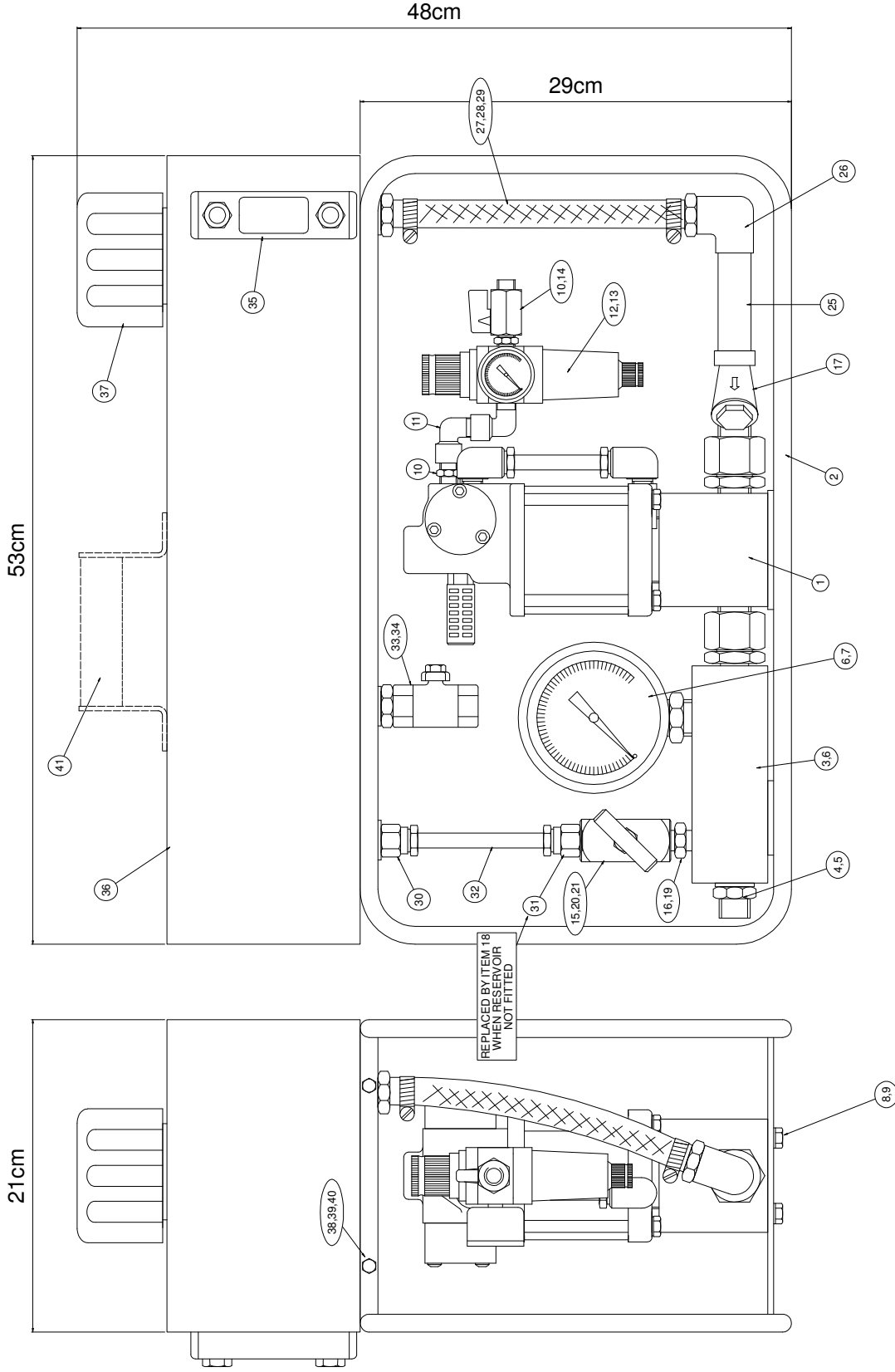

* 41	HANDLE (OPTIONAL)
* 40	WASHER
* 39	BOLT
* 38	NUT
* 37	FILLER CAP
* 36	RESERVOIR
* 35	SIGHT GLASS
* 34	DRAIN VALVE
* 33	ADAPTOR
* 32	COPPER PIPE
* 31	TANK CONNECTOR
* 30	CONNECTOR
* 29	HOSE CLIP
* 28	HOSE
* 27	HOSE BARB
* 26	ELBOW
* 25	EXTENSION PIPE
24	
23	
22	SEALING WASHER
20	BUSH
19	SEALING WASHER
18	ELBOW (only without reservoir)
17	STRAINER
16	ADAPTOR
15	RELEASE VALVE
14	BALL VALVE
13	AIR GAUGE
12	AIR FILTER/REGULATOR
11	ELBOW
10	ADAPTOR
9	WASHER
8	BOLT
7	HYDRAULIC GAUGE
6	SEALING WASHER
5	BONDED WASHER
4	OUTLET CONNECTOR
3	MANIFOLD
2	FRAME
1	PUMP
	ITEM DESCRIPTION

ITEM	DESCRIPTION	QTY.
47	O RING	1
46	RETAINING RING	1
45	SEALING WASHER	2
44	NON RETURN VALVE	2
43	HYDRAULIC CYLINDER	1
42	SCREW	1
41	BACK UP WASHER	1
39	HYDRAULIC SEAL	1
38	ANTI EXTRUSION RING	1
37	HYDRAULIC RAM	1
36	CONNECTING STUD	1
35	SLEEVE	1
34	LABEL	1
33	SOFT PLUG	1
32	END CAP, RETURN	1
31	GRUB SCREW	1
30	WASHER	4
29	BOLT	4
28	RETURN PISTON	1
27	U RING	1
26	O RING	1
25	MAIN VALVE SPOOL	1
24	SEALING RING	4
23	CAGE	5
22	O RING	2
21	LOCATING DISC	2
20	SCREW	6
19	END CAP, SIGNAL	1
18	PLUG	2
17	SIGNAL PISTON	1
16	U RING	1
15	O RING	4
14	BOTTOM COVER	1
13	PILOT SHAFT	1
12	BUSH	1
11	O RING	3
10	AIR PIPE	1
9	AIR CYLINDER	1
8	ELBOW	2
7	PISTON	1
6	O RING	1
5	CIRCLIP	1
4	O RING (4.4 on 2.2 ratio pump)	2
3	SILENCER	2
2	TOP COVER/VALVE BODY	1
1	DESCRIPTION	QTY.

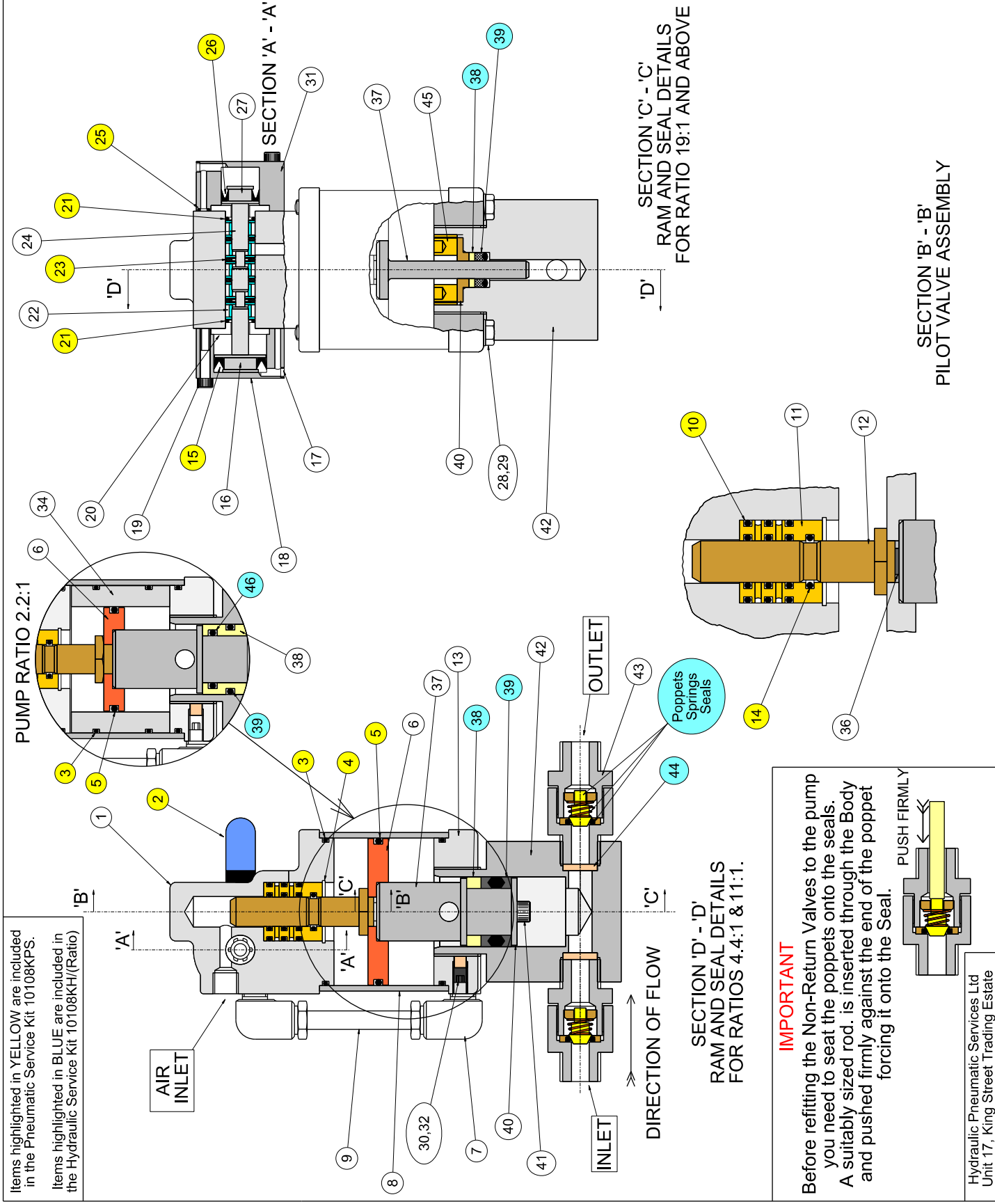

IMPORTANT
 Before refitting the Non-Return Valves to the pump you need to seat the poppets onto the seals. A suitably sized rod, is inserted through the Body and pushed firmly against the end of the poppet forcing it onto the Seal.

PUSH FIRMLY

Hydraulic Pneumatic Services Ltd
 Unit 17, King Street Trading Estate
 Middlewich, Cheshire, UK. CW10 9LF
 Telephone: +44 (0)1606 835725
 www.trojanpumps.com